

BLU
DOT

ONE NIGHT STAND

ASSEMBLY NOTES

A REAL
FLIP-FLOPPER

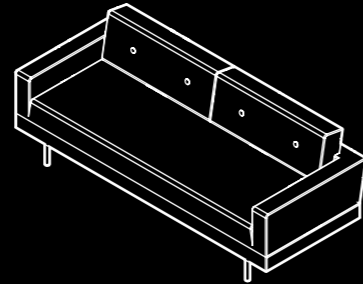

1

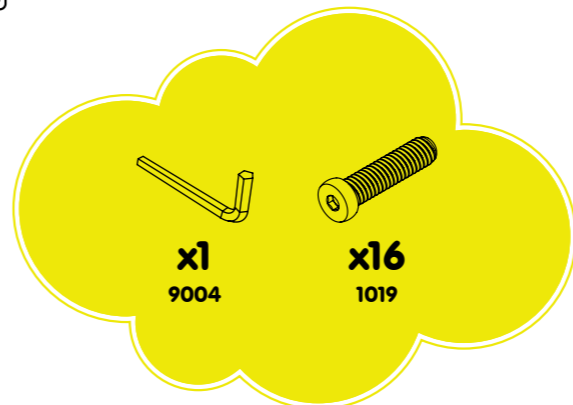

Straight Leg:
Front of Sofa

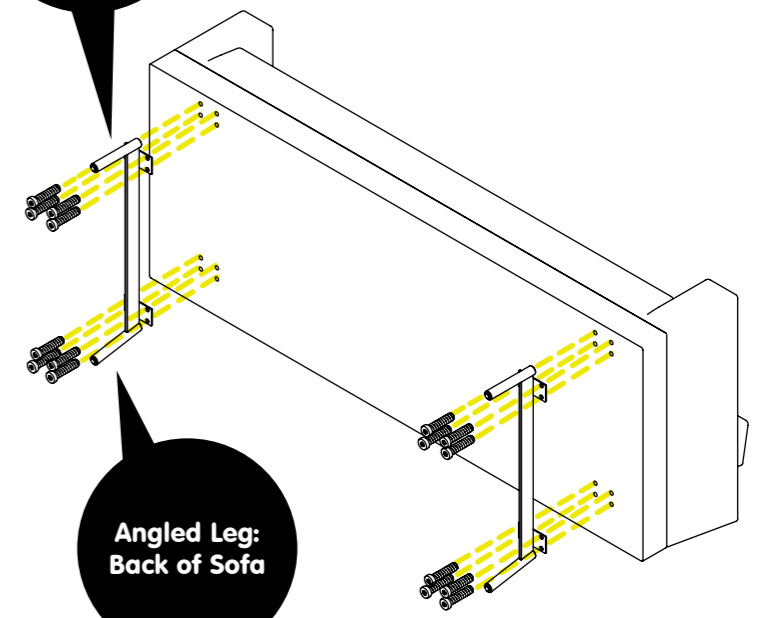

Angled Leg:
Back of Sofa

PARTS

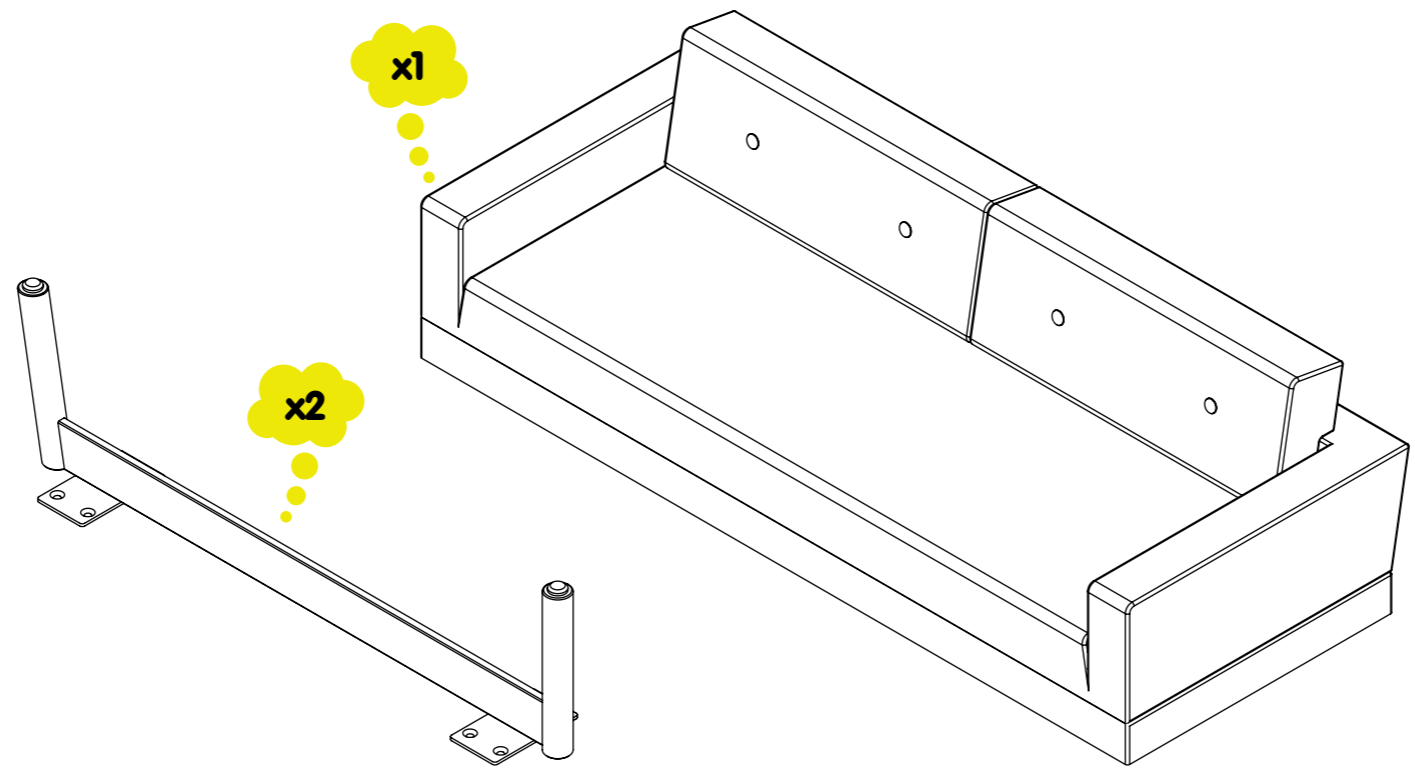

HARDWARE

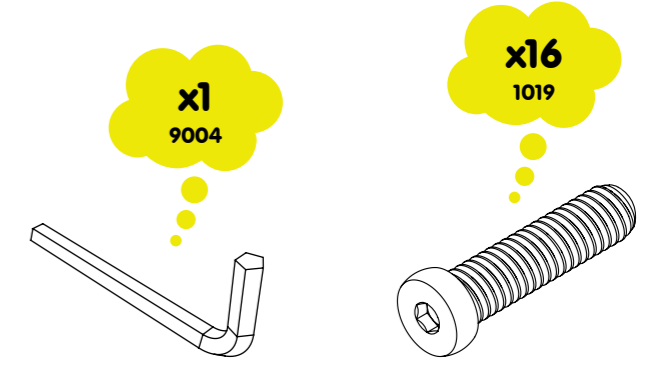



NOTE

To convert the sofa into a sleeper follow these simple steps.

Use the buddy-system: it takes two people.

1
Remove Pillows



SIDE VIEW

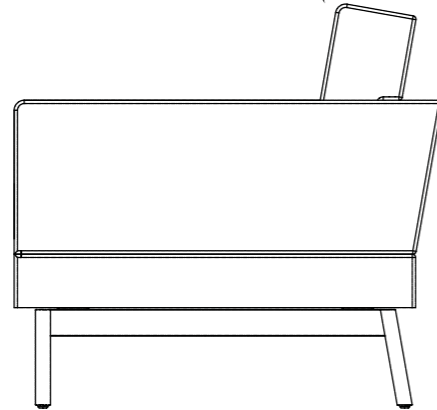

2
Flip Seat Forward

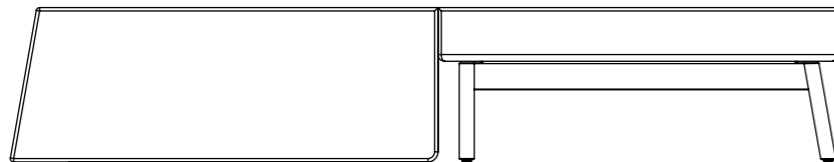
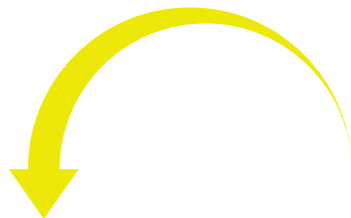

CARE



CLEAN

Vacuum your upholstery regularly.

SPILLS

Act quickly with spills. Absorb the spill with a clean white cloth or paper towel. Never rub the surface. Spot clean with dry cleaning fluid. Do not use water or other liquids to clean, as they may stain the fabric. Consult a commercial cleaning specialist for removal of stubborn stains.

AVOID

Keep upholstery & felt furniture out of direct sunlight and away from heat sources; excessive exposure to sunlight will fade the color of the upholstery. Avoid placing heavy or sharp objects on the furniture surface for long periods of time; this can cause permanent indentations in the fabric. For snags in the fabric, tuck loose threads into fabric or carefully push to reverse side. Never pull out or cut off loose threads.