

Moreover Extension Dining Table

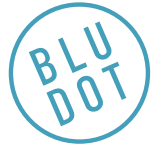

DESIGNED IN 2021

ASSEMBLY NOTES | REV 02

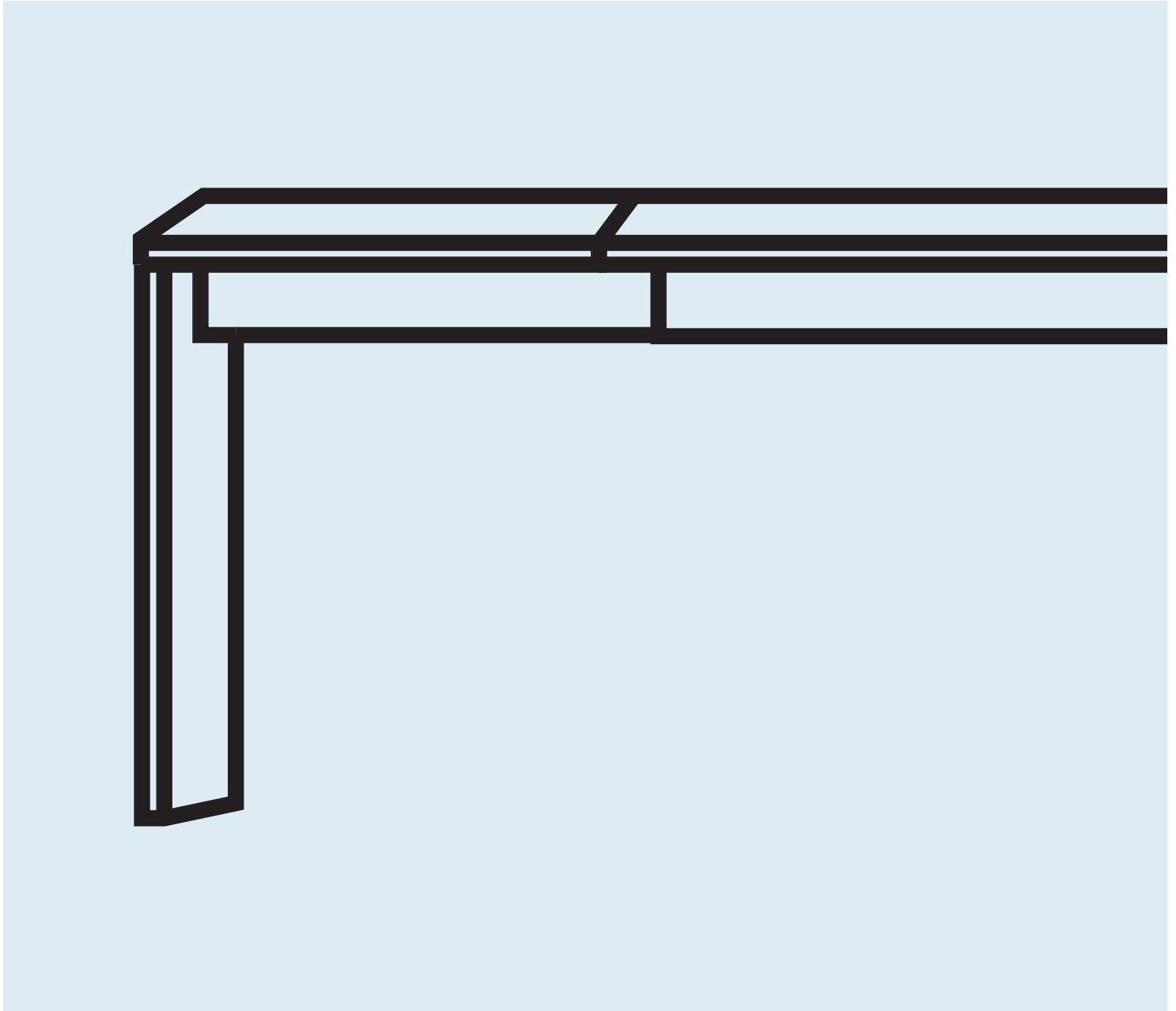

NEED A HAND?

Contact us at service@bludot.com or
844.425.8368 for assistance.

@BLUDOT

We design all our pieces in our Minneapolis studio. Follow
along on Instagram for some sneak peeks into the process.

Parts & Hardware

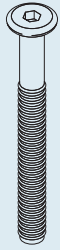

QTY 2

Pt. 1617



QTY 5

Pt. 1618

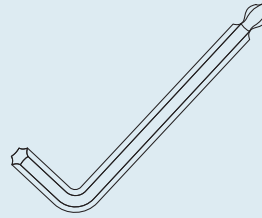

QTY 1

Pt. 9017

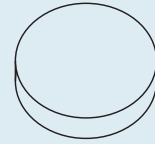

QTY 8

Foot Pad

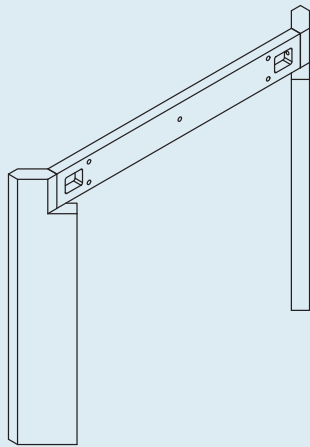

QTY 1

Pull Out Legs



QTY 2

Stationary Leg

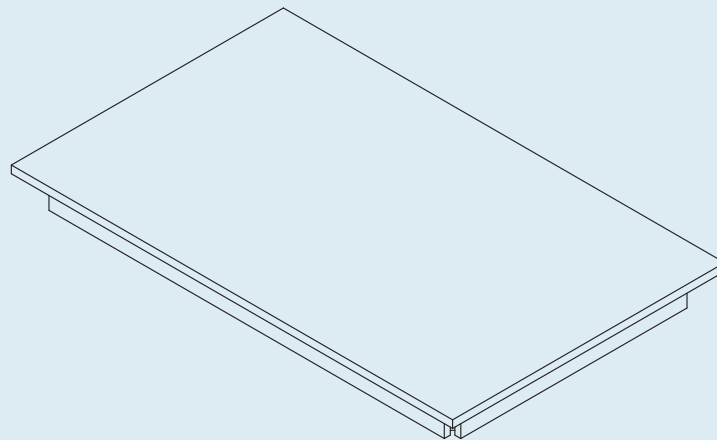

QTY 1



Top

Step 01

ATTACH THE LEGS.

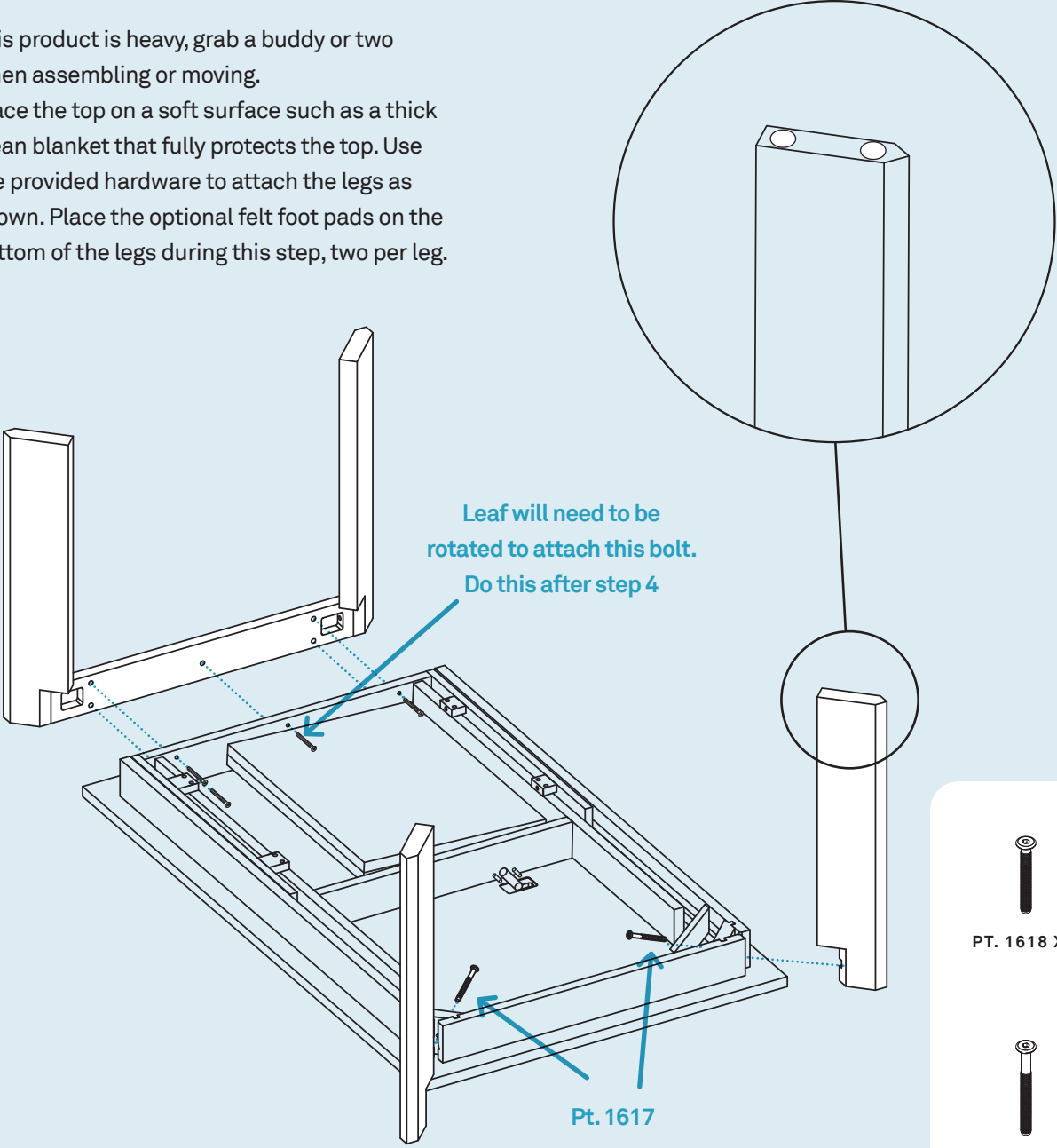
This product is heavy, grab a buddy or two when assembling or moving. Place the top on a soft surface such as a thick clean blanket that fully protects the top. Use the provided hardware to attach the legs as shown. Place the optional felt foot pads on the bottom of the legs during this step, two per leg.



- 
PT. 1618 X 5
- 
PT. 1617 X 2
- 
PT. 9017 X 1

Step 02

TURN THE TABLE UPRIGHT.

Please have two or more people perform this step.

Make sure the mechanism is locked before lifting the table. Check if the handle is completely rotated in the locked in the position shown.

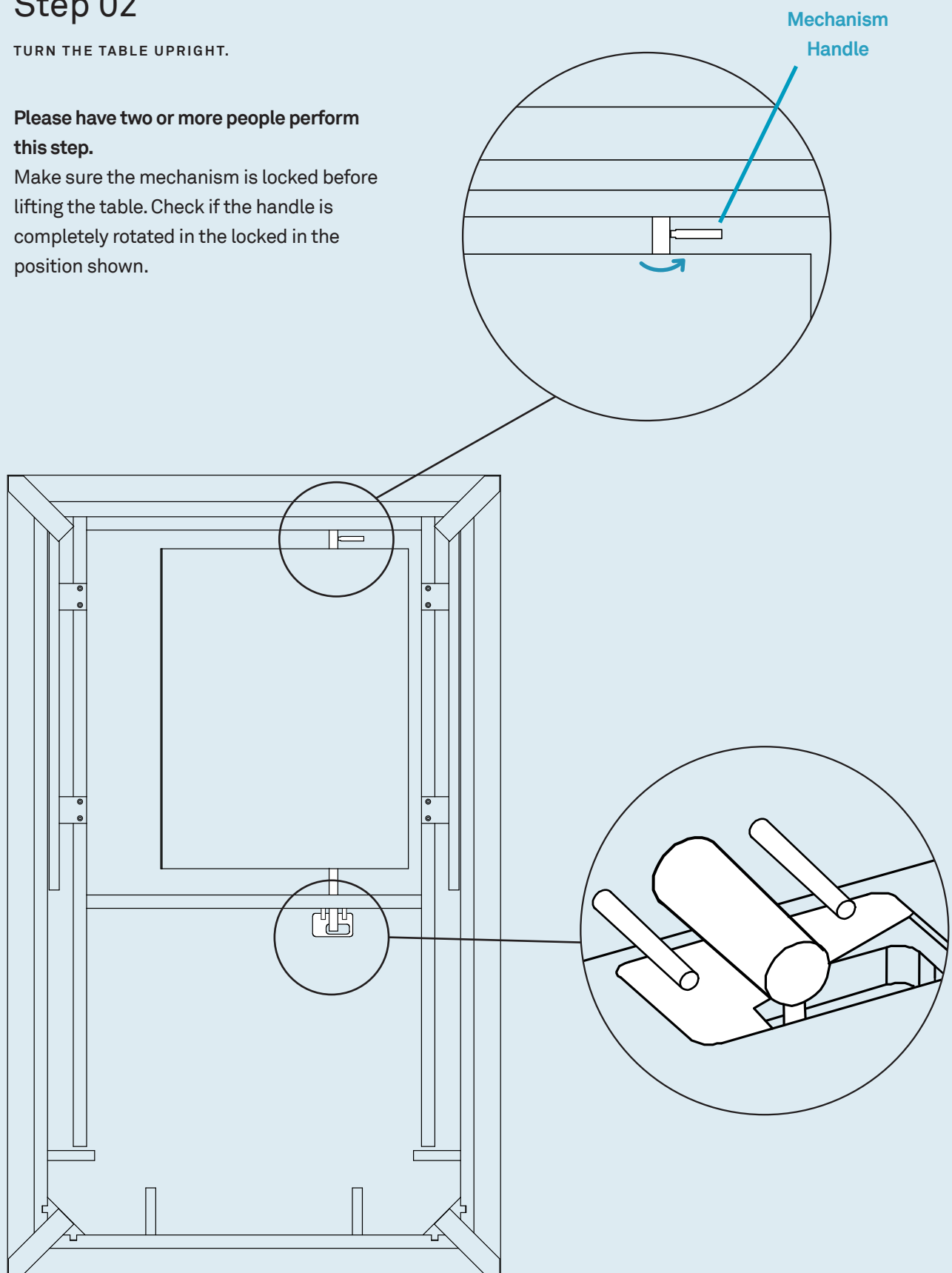

Step 03

UNLOCKING AND PULLING OUT THE LEGS.

(A) Unlock the table by rotating the handle down and clockwise.

(B) Carefully lift and pull the legs out until they stop and the butterfly leaf is fully exposed.

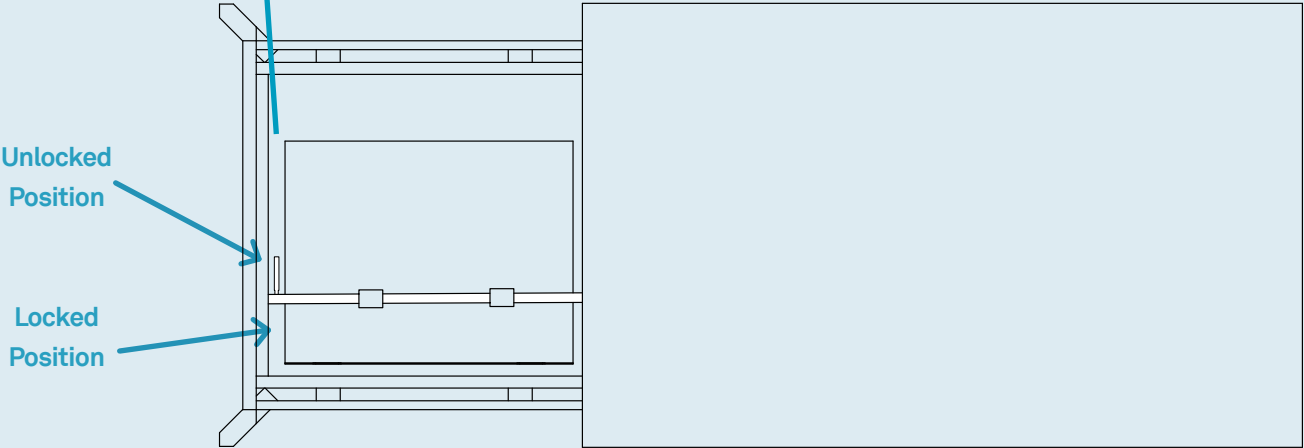
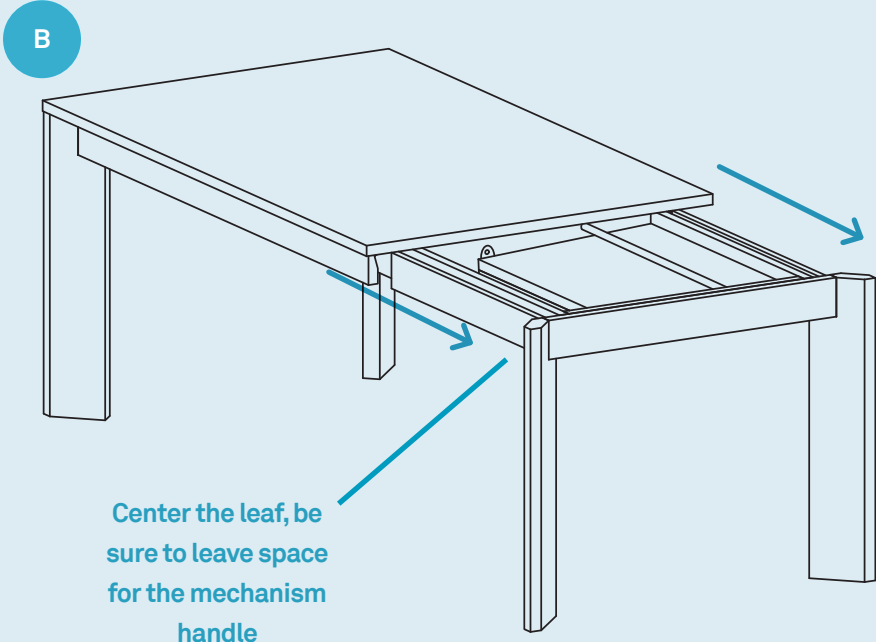
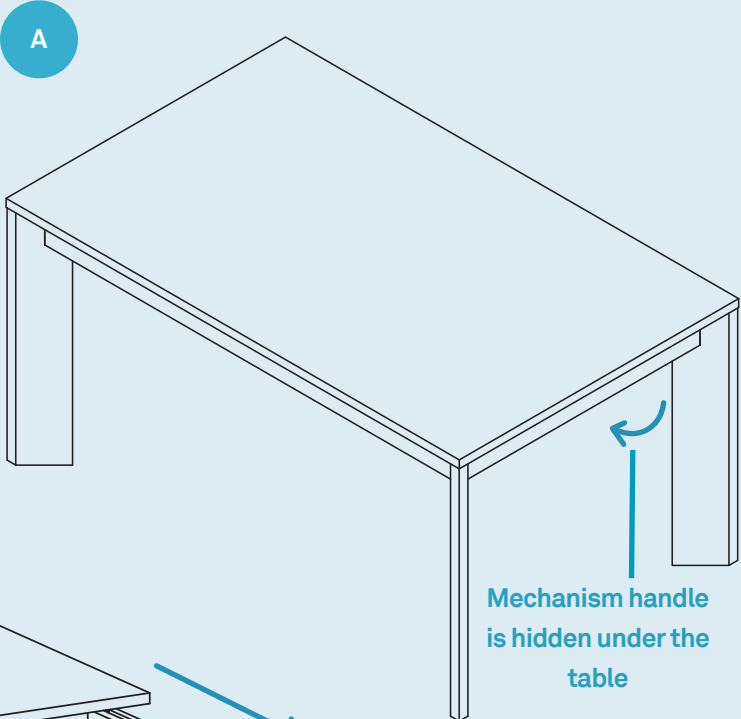

Step 04

UNFOLD AND LOCK THE LEAF.

(A) Gently unfold the leaf. Be sure the handle remains below the leaf when unfolding.

(B) Lift and push the legs inward until snug. Lock the table by rotating the handle counterclockwise.

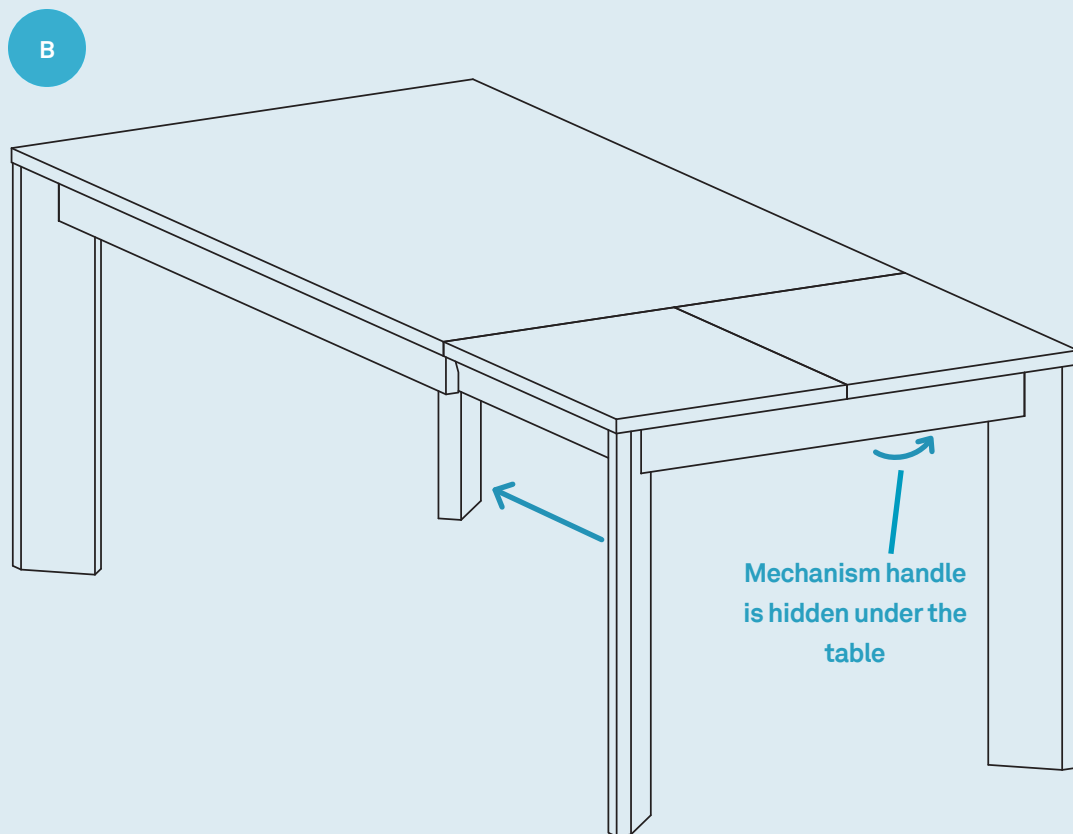
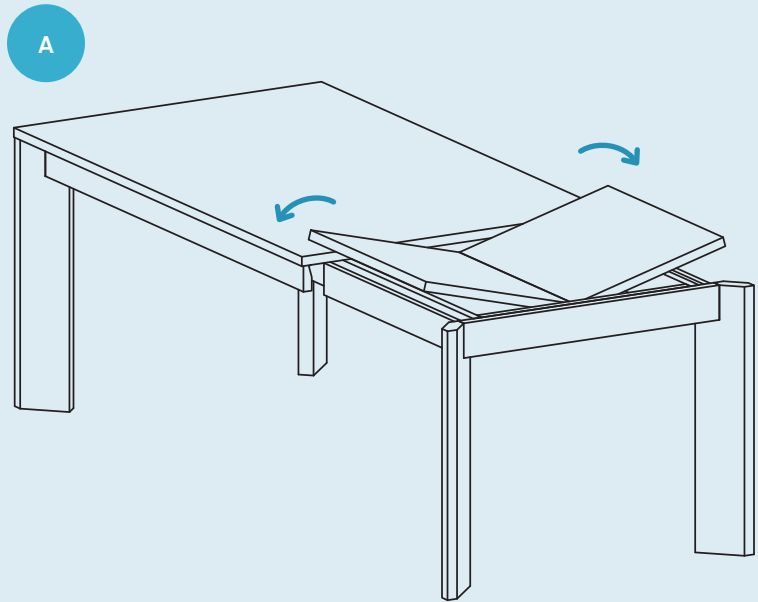

Step 05

CLOSING THE TABLE.

Perform steps three and four in reverse order, starting with unlocking the table.

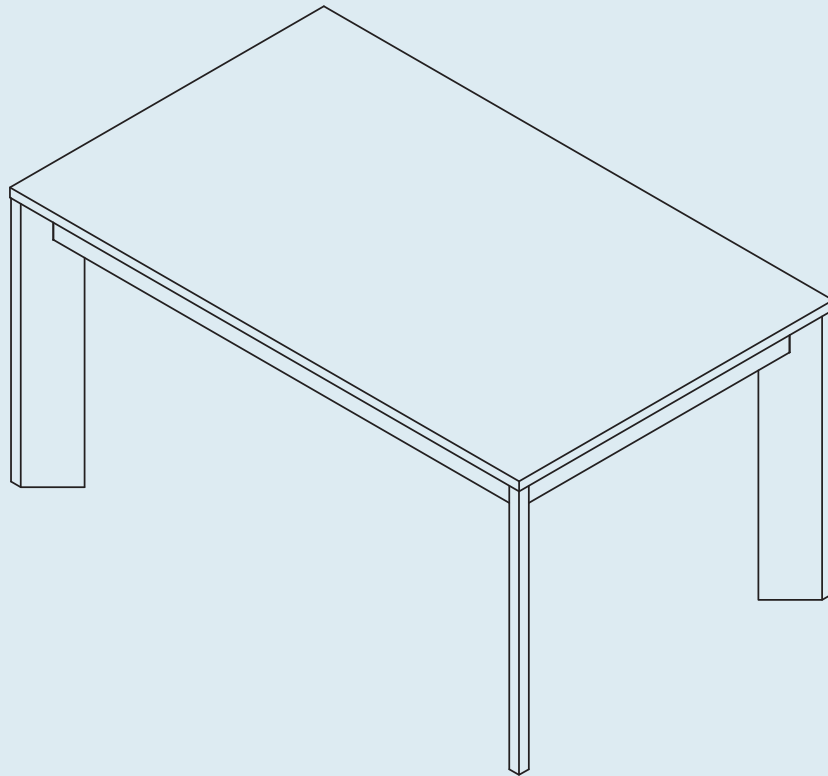

Additional Information

CLEANING AND PROTECTION

Clean with a slightly damp, soft cloth. To remove dirt and fingerprints, use a quality cleaner formulated for wood furniture. Wipe completely dry with a soft cloth in the direction of the wood grain.

Avoid staining. Clean up spills immediately by using a blotting rather than a wiping action. Liquids left over a long period of time may cause white spots in the finish.

To avoid fading, keep your furniture out of direct sunlight. Do not place directly under windows. Periodically rotate accessories on furniture, so they don't always sit in the same spot.

Avoid wood stress from extreme temperature and humidity changes by arranging furniture away from radiators, heat and air vents, and air conditioning units.

Use cloth/felt pads to protect the furniture surface from hot dishes, heavy, and sharp objects as they may damage the finish.

