

BLU  
DOT

# DAILY TASK CHAIR

ASSEMBLY NOTES

FOR THOSE SITTING  
ON THE DAILY!

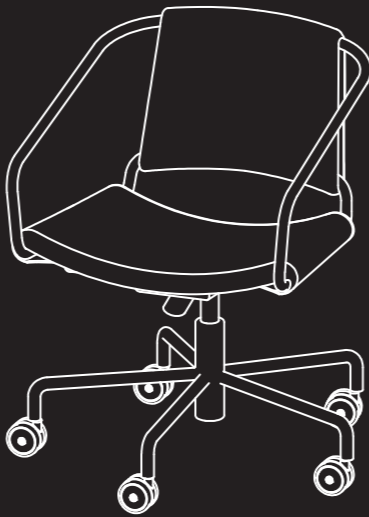
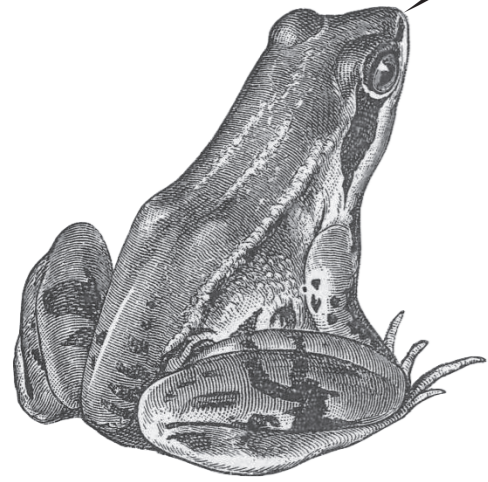

## PARTS & HARDWARE

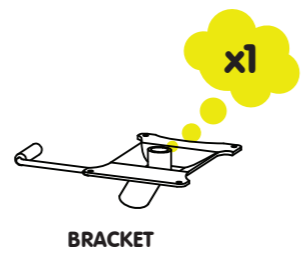
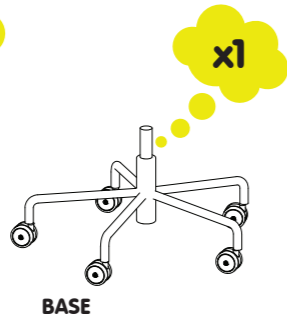

1

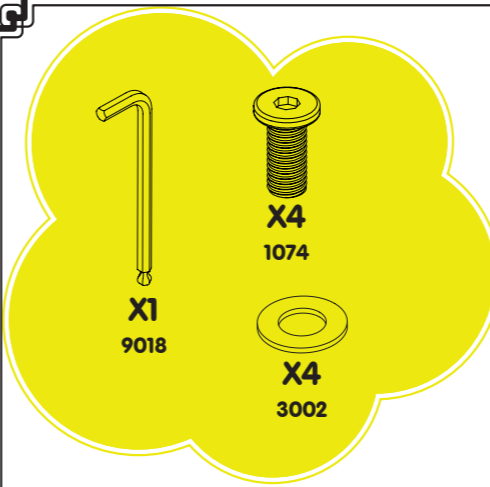

\*  
Bracket arrow  
indicates chair  
front.

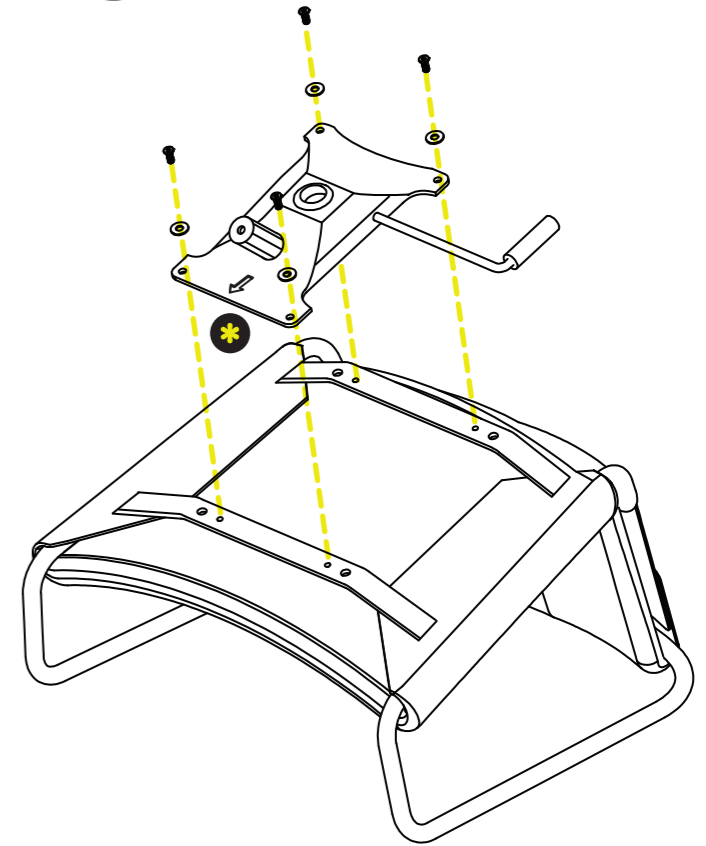

2

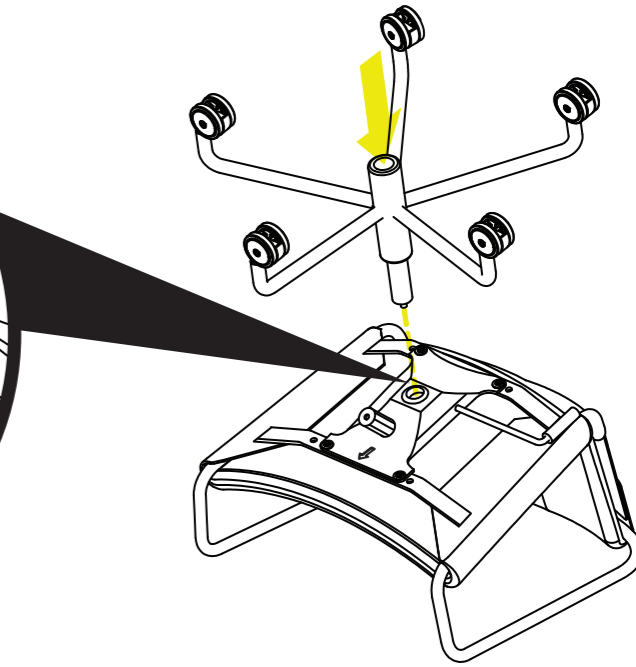
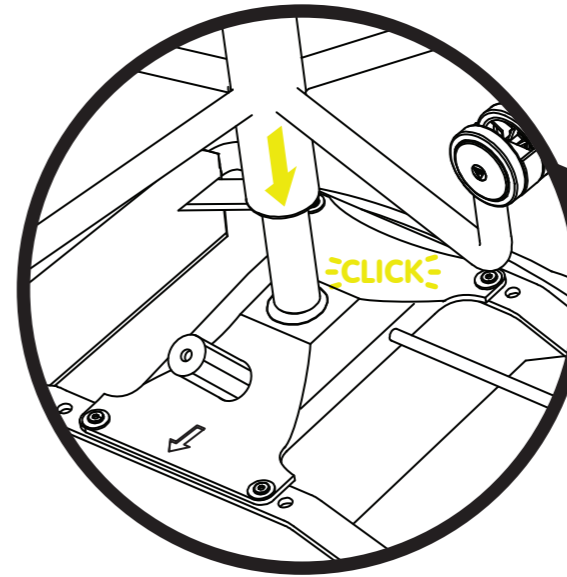

3

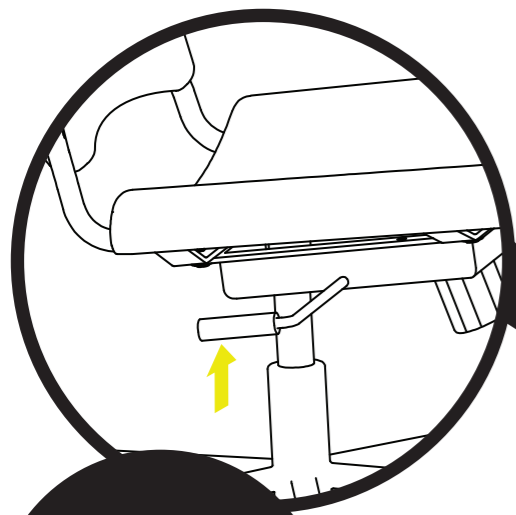

**HEIGHT ADJUSTMENT**  
Pull tilt lock arm up for height adjustment.

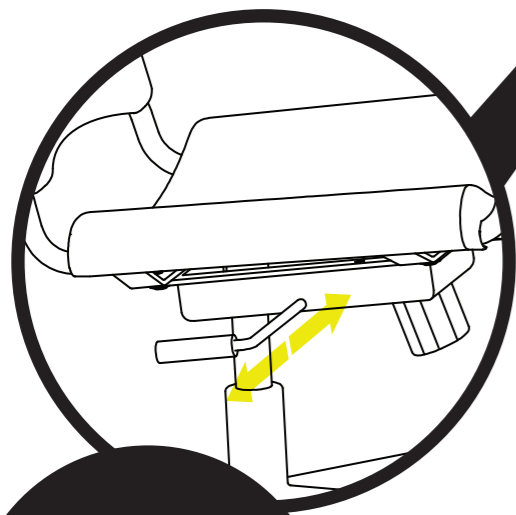
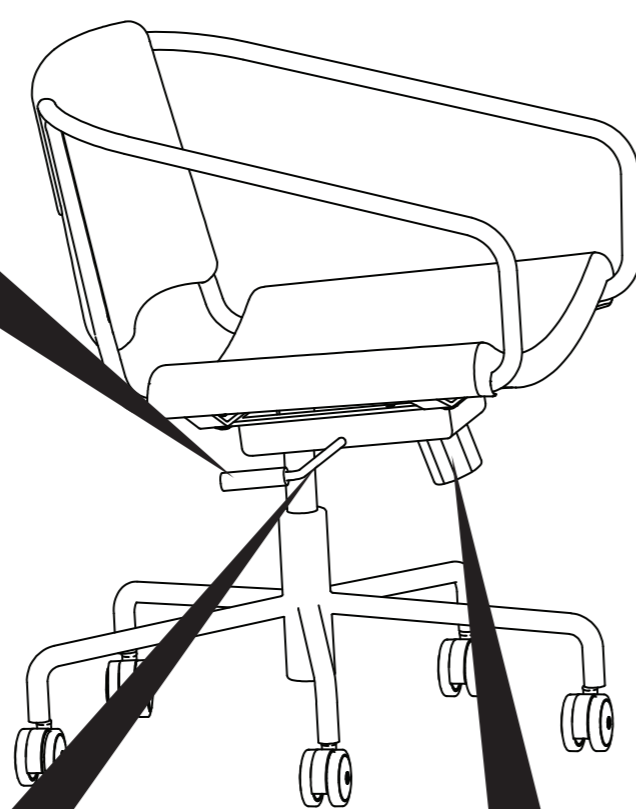

**TILT LOCK**  
Push tilt lock arm in to lock chair in upright position. Pull tilt lock arm out for backward tilt.

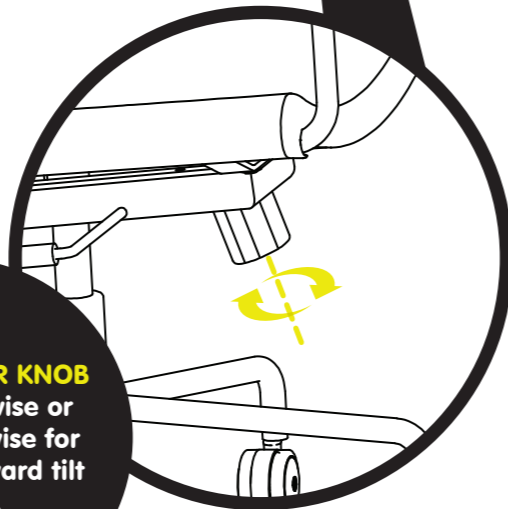

**TILT TENSIONER KNOB**  
Rotate clockwise or counterclockwise for desired backward tilt tension.



**SPILLS**

Act quickly with spills. Absorb the spill with a clean white cloth or paper towel. Never rub the surface. Consult a commercial cleaning specialist for removal of stubborn stains.

**UPHOLSTERY & FELT CARE**

**KEEP IT CLEAN, JIMMY!**

**AVOID**

Keep upholstery & felt furniture out of direct sunlight and away from heat sources; excessive exposure to sunlight will fade the color of the upholstery. Avoid placing heavy or sharp objects on the furniture surface for long periods of time; this can cause permanent indentations in the fabric. For snags in the fabric, tuck loose threads into fabric or carefully push to reverse side. Never pull out or cut off loose threads.